

2024 – 2025

COURSE CALENDAR



GUIDO DE BRÈS

CHRISTIAN HIGH SCHOOL

Guido de Brès Canadian Reformed High School Society
350 Albright Road, Hamilton, ON, L8K 5J4
Telephone: (905) 574-4011
Website: www.guidodebres.org
Email: office@guidodebres.com

GUIDO DE BRÈS CHRISTIAN
HIGH SCHOOL

Course Calendar

2024 – 2025

TABLE OF CONTENTS

VISION STATEMENT	2	RELIGIOUS STUDIES	17
DIPLOMA REQUIREMENTS	3	PHILOSOPHY	17
INTRODUCTORY NOTES	4	CLASSICAL STUDIES	17
COURSE DESCRIPTIONS		MATHEMATICS	18
THE ARTS		HEALTH AND PHYSICAL EDUCATION	19
Drama	10	SCIENCE	
Music	11	Science	20
Visual Arts	11	Biology	20
Integrated Arts	12	Chemistry	21
BUSINESS AND COMPUTER STUDIES	12	Physics	21
CANADIAN AND WORLD STUDIES		TECHNOLOGICAL EDUCATION	21
Geography	13	FAMILY STUDIES	22
History	13	COOPERATIVE EDUCATION	22
Civics	14		
Law	14		
ENGLISH	14		
GUIDANCE AND CAREER EDUCATION	16		
FRENCH	16		

For further information pertaining to Guido de Brès Christian High School, please consult the *Parent Handbook*.

Guido de Brès Christian High School Vision Statement

1. Purpose and Foundation

Members of the Canadian Reformed Churches have established Guido de Brès Christian High School so that the schooling provided will assist the parents in the fulfillment of the promises made at the baptism of the covenant children entrusted to their care. Reformed education aims to realize this assistance by equipping the students to employ their talents in the service of God and His Kingdom. The following statements indicate how this most basic aim is to be achieved and thus constitute the basis of the instruction which Guido de Brès Christian High School seeks to provide:

- a) The entire curriculum will be taught in obedience to the Holy Scriptures, the infallible Word of God, as confessed in the Three Forms of Unity (the Belgic Confession, the Heidelberg Catechism, and the Canons of Dort).
- b) Each subject in the curriculum will have as its point of departure the cultural mandate: the command to subdue the earth as clearly stated in the book of Genesis and elaborated upon in the entire Scriptures.
- c) All teaching will take into account that this cultural mandate is to be exercised in a world which is lost in the misery and guilt incurred by man's fall into sin but overcome by the work of our Lord and Saviour Jesus Christ.

2. Specific Aims and Objectives

It is the special task of Guido de Brès Christian High School to provide a program of instruction appropriate to the secondary level of education and, in so doing, to:

- a) teach the students about all aspects of God's created order, that they may stand in awe of their Maker and praise Him;
- b) remind the students that their calling in this world is to know God as their Creator, Redeemer, and Sanctifier and to honour and serve Him;
- c) help the students grow into mature human beings, prepared to employ their talents in the service of God and for the benefit of their neighbours, in all areas of life;
- d) assist the students in recognizing their value and privileges as God's covenant children, and remind them that they are enabled by grace to respond in obedience to the call to serve;
- e) help the students develop a Christian mind, so that they may discern the power and corrupting influence of secular or seemingly Christian philosophies and, in submission to the Lordship of Christ, with due humility begin to think in a Reformed way about all aspects of life;
- f) remind the students that, because of the redeeming work of Christ, this world has not been abandoned by God and that their work as His followers and co-workers is therefore of value for the coming restoration of God's Kingdom on this earth;
- g) show the students that knowing and fearing God is essential to attaining true knowledge and wisdom, since teaching and learning are bound up with one's relationship to God.
- h) challenge students to demonstrate, in daily talk and action, a Christian heart sincerely responding to the call to follow Christ.

These foundational statements are summarized by our motto *Everything in Christ*. All things, including the instruction of Guido de Brès Christian High School are subject to his rule and authority.

These aims and objectives indicate the importance and value of completing a secondary education. The school and its teachers are committed to helping every student have a successful outcome from their secondary school experience.

DIPLOMA REQUIREMENTS

MINISTRY OF EDUCATION REQUIREMENTS FOR THE GRANTING OF DIPLOMAS AND CERTIFICATES

1. The Requirements for the Ontario Secondary School Diploma (OSSD)

Students must meet the following requirements in order to obtain the Ontario Secondary School Diploma:

18 compulsory credits:

4	in English*	1	in the arts
3	in mathematics	1	in health and physical education
2	in science	1	in French as a second language
1	in Canadian history	0.5	in civics
1	in Canadian geography	0.5	in career studies

(For students entering high school September 2024 or later: 1 credit in Technological Education)

Plus one credit from each of the following groups:

- Group 1:* one additional credit in English, or French as a second language, or a native language, or a classical or an international language, or social sciences and the humanities, or Canadian and world studies, or guidance and career education, or cooperative education
- Group 2:* one additional credit in health and physical education, or the arts, or business studies, or French as a second language (if not used as the Group 3 requirement), or cooperative education
- Group 3:* one additional credit in senior science, or technological education, or French as a second language (if not used as the Group 2 requirement), or cooperative education

See Introductory Notes #9 for information regarding substituting compulsory credits.

In addition to the compulsory credits, students must complete

- 12 optional credits
- 40 hours of community involvement activities (see the school website for details)
- two credits as online credits (beginning with students who entered Grade 9 in 2020-21)**
- the provincial literacy requirement

Students will normally take the compulsory literacy test in Grade 10. It is based on the Ontario curriculum expectations for language and communication – particularly reading and writing – up to and including Grade 9.

* A maximum of three credits in English as a second language (ESL) or English literacy development (ELD) may be counted towards the four compulsory credits in English, but the fourth must be a credit earned for a *Grade 12* compulsory English course. (Note that our school does not offer ESL or ELD.)

**Guido de Brès Christian High School has decided to exempt all students from the graduation requirement of two online learning credits as we believe that this requirement strongly conflicts with both the religious and educational mission of the school. This exemption will be included in the Ontario Student Record of each student. On the student transcript it will be recorded as "Online Graduation Requirement- N/A".

2. The Ontario Secondary School Certificate

The Ontario Secondary School Certificate will be granted on request to students who leave school before earning the Ontario School Diploma, provided that they have earned a minimum of 14 credits distributed as follows:

7 compulsory credits:

- 2 in English
- 1 in Canadian geography or Canadian history
- 1 in mathematics
- 1 in science
- 1 in health and physical education
- 1 in the arts or technological education

7 optional credits

The provisions for making substitutions for compulsory credits described in Introductory Notes #9 also apply to the Ontario School Certificate.

3. The Certificate of Accomplishment

Students who leave school before fulfilling the requirements for the Ontario Secondary School Diploma or the Ontario Secondary School Certificate may be granted a Certificate of Accomplishment.

INTRODUCTORY NOTES

1. Curriculum Streaming

In Grade 9, courses are de-streamed, meaning that all students take the same Grade 9 courses. In Grade 10, courses are offered in the Academic, Applied or Open streams. In grades 11 and 12, the streaming is University, Mixed (University/College), College, and Workplace.

Academic courses develop students' knowledge and skills by emphasizing theoretical, abstract applications of the essential concepts while incorporating practical applications as appropriate.

Applied courses develop students' knowledge and skills by emphasizing practical, concrete applications of the essential concepts while incorporating theoretical applications as appropriate.

University-Preparation courses are designed to equip students with the knowledge and skills they need to meet the entrance requirements for university programs.

University/College-Preparation courses include content that is relevant to both university and college programs.

College-Preparation courses are designed to equip students with the knowledge and skills they need to meet the entrance requirements for college programs.

Workplace-Preparation courses are designed to equip students with the knowledge and skills they need for direct entry into the workplace or for admission to apprenticeship programs offered in the community.

Open courses are appropriate for all students and are not linked to any post-secondary destination.

2. Educational Assistance

Normally, an Educational Assistant is assigned to some Grade 9 classes and to Grade 10 applied stream classes, as well as many Grade 11 and 12 college stream classes. At the school's discretion, individual accommodations may be made in the teaching/learning process to allow demonstration of grade level expectations. Accommodations change *how* we teach and assess, not *what* we teach and assess. Examples include using assistive technology, scribing, granting extra time to complete work, etc.

3. Considerations in Selecting Programs

In selecting their program, students should be guided by such considerations as interest, aptitude, requirements of post-secondary institutions, and career choice.

Success in job application and admission to post-secondary institutions will often be determined by the courses students have taken and the marks they have received. In other words, a high school diploma is not in itself the key that opens the door to acceptable employment or further education. Students should keep this in mind from the start of their high school career. Above all, students should recognize that everyone has been granted talents and given the responsibility to use them to the utmost of his or her ability in obedience to God's Word.

4. Course Codes

Course codes are assigned by the Ministry of Education and are used in all Ontario secondary schools. The characters of the 5 or 6 digit code indicate the following information:

1 – 3 subject area and course

4 grade: 1 = 9
2 = 10
3 = 11
4 = 12

5 streams:

W = De-streamed
D = Academic
P = Applied
U = University Preparation
M = University/College Preparation
C = College Preparation
E = Workplace Preparation
O = Open

Example:
AMU30
AMU = Music
3 = grade 11
O = Open

5. Credits

A credit is granted in recognition of the successful completion of a course that has been scheduled for a minimum of 110 hours. Unless otherwise indicated, all courses listed in this calendar are worth one credit each.

6. Student Evaluation

The following method is used to report student performance.

Percentage Grade Range	Letter Grade	Description
80-100%	A	Level 4: A very high to outstanding achievement above the provincial standard.
70-79%	B	Level 3: A high level of achievement; the provincial standard.
60-69%	C	Level 2: A moderate level of achievement below but approaching the provincial standard.
50-59%	D	Level 1: A passable level of achievement below the provincial standard.
Below 50%	E	Insufficient achievement; no credit granted

At the end of the each semester, students will participate in a culminating experience in each course that consolidates material learned for each semester. Culminating activities account for 30% of the final mark. Normally, Academic and University courses will have a 30% exam and Applied, College and Workplace preparation courses will have a 20% exam and 10% for another culminating activity.

All students must write exams in designated courses at the end of both semesters. All exams are two hours in length. Students have the opportunity to review their completed exam with their teachers up to three months after the exam date.

7. Class Schedule

There will be a bell to indicate the beginning and end of every class. During the rotation time between, students may visit the washrooms and go to their lockers. The normal schedule is:

- Period 1: 8:55 to 10:18
- Period 2: 10:25 to 11:40
- Lunch: 11:45 to 12:30
- Period 4: 12:35 to 1:48
- Period 5: 1:55 to 3:10
- Last bell: 3:12

Each student will receive a timetable in the summer and at the beginning of each semester. Every other day the morning classes are in opposite order as are the afternoon classes.

8. Cancellation of Courses

During any school year, Guido de Brès Christian High School reserves the right to cancel courses for which enrolment is too low or no instructor is available.

9. Course Transfers, Changes and Substitutions

If students wish to transfer to a course for which they have not earned the prerequisite credit, they need special permission to do so. Students may request to make such a change by contacting the Vice-principal (Academics). Approval for such a request will be made after discussion with the relevant department head, the student's previous teacher(s), the student, and the student's parent. If approval is granted, a "Waiving of a Prerequisite" form will be completed and retained in the student's OSR.

Students have up to four days after the start of a new semester to request a course change.

In order to obtain an OSSD, students must earn a minimum of 30 credits, 18 of which are compulsory. The principal may substitute up to three compulsory credits with other credits. Substitutions should be made to promote and enhance student learning or to respond to special needs and interests. The principal's decision to substitute one course for another is made only if the student's educational interests are best served by such a substitution. The following are limitations on substitutions for compulsory credits:

- English as a second language and English literacy development courses may not be used to substitute for a compulsory credit.
- No more than one learning strategies course, from the guidance and career education curriculum policy document, may be used through substitution to meet a compulsory credit requirement.
- Credits earned for cooperative education courses may not be used through substitution to meet compulsory credit requirements.
- A locally developed compulsory credit (LDCC) course may not be used as a substitute for a compulsory credit; it may be used only to meet the compulsory credit requirement that it has been designed to meet.

If a student (including a student with an Individual Education Plan) withdraws from a Grade 11 or 12 course within five instructional days following the issue of the first report card, the

withdrawal is not recorded on their transcript. If a student withdraws from a course after five instructional days following the issue of the first report card, the withdrawal is recorded on the transcript. The student's percentage grade at the time of the withdrawal is recorded in the "Percentage Grade" column. Withdrawals from Grade 9 or 10 courses are not recorded on the transcript.

10. Student Reporting and Student Records

Each semester is divided into two terms. Students will receive two reports per semester, one at the end of each term. This student evaluation is the result of judging the quality of a student's work based on established achievement criteria following assessment practices described in *Growing Success*. All reports include percentage or letter grades and comments about work habits. At the end of each semester, the number of community involvement hours the student has earned and whether or not the student has successfully completed the provincial literacy test will also be communicated.

The school keeps an Ontario Student Record (OSR) file for each student. This file contains achievement results, credits earned and diploma requirements completed. Students and their parents (if the student is not an adult) may examine the contents of the OSR. These records are protected by the Education Act and freedom of information legislation.

The Ontario Student Transcript (OST) provides a comprehensive record of a student's overall achievement in high school. The OST records all the credits and marks that a student has earned, plus an indication if the requirements for 40 hours of community involvement activities have been completed.

11. Other Course Options: AP, IB, ILC, co-op, PLAR

The school does not offer Advanced Placement and International Baccalaureate courses are not available at our school.

Students are able to apply for courses from the Independent Learning Centre or another distance education provider with permission from the principal. Normally permission will only be granted if the student requires a course not offered by the school. If the course is a requirement for a student's diploma or post-secondary goals but cannot be offered by the school, the fee for the course will be reimbursed upon successful completion of the course; in all other cases, the school will not pay the fee for the course. See the Student Services office for full details. If a Grade 12 student takes an ILC course that is required for graduation, Guido needs to have confirmation of the final mark in the course by early June.

The school offers co-operative education. Refer to the description on the last page of this booklet. Work experience for partial credit outside of the existing co-operative education program is not offered by the school.

Prior Learning Assessment and Recognition (PLAR) is the formal evaluation and credit granting process whereby students may obtain credits for prior learning. Prior learning includes the knowledge and skills acquired outside of secondary school. At present, the school grants credits using PLAR only in the case of

students joining Guido after being home schooled or coming from a different educational jurisdiction.

Students in publicly-funded schools in Ontario are required to earn two credits through online schooling. Guido de Brès Christian High School has decided not to participate in this since our school is committed to assisting the parents of our supporting church communities to raise their children in the fear of the Lord. As such, the community supports an in-person educational platform where curriculum is infused with a Reformed Christian world view, taught by teachers who share our core religious values, and experienced in a community of in-person learners. Having a portion of that education provided outside the school setting is not in line with our school's core mission. Further, having our students taught by instructors who are not members of our church community goes against the founding principles of our school society.

12. Ontario Secondary School Literacy Test and Course

Students will normally write the Ontario Secondary School Literacy Test (OSSLT) during the second semester of their grade 10 year. Students who have an Individual Education Plan may be eligible for accommodations that change the way in which the OSSLT is administered. These accommodations do not alter the content of the test. Such accommodations must be indicated on the student's IEP. Special provisions are made also for English Language Learners. These students will take the OSSLT when they have acquired the level of proficiency in English required for success. This may result in a deferral. Other criteria that may result in a deferral of the test include: a recommendation from an IPRC to defer the test; a situation in which a student has not yet acquired the reading and writing skills appropriate for Grade 9; or an illness or injury for which appropriate accommodations are not available. Finally, an exemption is granted for students who are not working toward an OSSD as indicated on their IEP.

Students who unsuccessfully attempt the OSSLT are eligible to register in the Ontario Secondary School Literacy Course (OSSLC) as long as they have been eligible to write the OSSLT at least twice. See Student Services for details.

13. Evaluation and Examinations

Evaluation is based on the document *Growing Success*. As such, evaluation is fair, transparent and equitable for all students. Accommodations are provided for students with unique learning needs. Evaluation will provide students with a variety of opportunities to demonstrate their mastery of the curriculum expectations.

All courses end with a culminating task that comprises 30% of the final grade of the course. Thus, final examinations are weighted up to 30%. If a course has an examination, it will be written during the exam week. All examinations are 2 hours long.

During instruction and evaluation, the unique needs of English Language Learners will be accommodated.

14. Community Service Hours

All students must complete a minimum of 40 hours of volunteer community service before they graduate as a requirement to

earn the Ontario Secondary School Diploma. The main responsibility for organizing the program and making the required contact lies with the student and the parents. The purpose of this government-initiated program is to encourage students to develop awareness and understanding of civic responsibility and the role they can play in strengthening their local communities. Full details of the program (including suggestions of possible activities, a list of ineligible activities and recording forms) are available on the Guido website.

Note that doing unpaid work for a for-profit organization is not eligible. Further, community service hours may not be completed during hours of the day that a student is to be in class. In other words, students may not take time off school to complete community service hours.

15. School Support Services

The school has a library resource centre which is available to students from 8:00 a.m. to 4:00 p.m. The computer labs are available before school and during lunch for student use.

The school offers counselling services one day a week by a counsellor from the Christian Counselling Centre.

16. Guidance and Career Education Programs

All students must complete the Grade 10 Careers Course. Students in grade 9 will have a conference with the vice-principal to regarding their current performance and future plans. Students in grades 10 to 12 will have conferences with the school's head of student services. Grade 12 students will receive extra support in making choices about post-secondary options and applying to college and university.

Students will use myBlueprint to plan their high school pathway leading to their post-secondary goals. Meetings with the Student Services department will help ensure that students are meeting requirements for their pathway and, where that is not happening, assistance is available to find alternate pathways to success. More details are available from Student Services.

In October parents with students in grade 12 have the opportunity to meet with the head of student services to receive more information about post-secondary options.

A career day for grade 10 students is organized every year on the last Friday of March or first Friday in April. Students can sign up for eight different career presentations.

17. Code of Student Behaviour

Guido de Brès Christian High School recognizes that all people are created in the image of God. Thus, we promote a safe school environment by encouraging all students to show love and respect within the school community. Guido aims to ensure that all students feel valued, respected and connected within the school community.

.1 Expectations for Students

Students will

- a. show honour and respect to all staff members and be obedient to their instructions.

- b. cooperate with and address their peers in a positive manner, and so promote freedom from physical, verbal, and sexual harassment.
- c. enter classrooms at the correct time in a proper manner and be properly prepared for each class.
- d. confine themselves to designated areas and demonstrate acceptable and courteous behaviour at all times.
- e. work diligently to complete their required courses to the maximum of their potential.
- f. show due respect and care for school property and the property of all staff members and fellow students.

.2 Teachers' and School Office's Roles

Teachers' Role: Teachers have the most important role in implementing the school's discipline policy. They will use the following steps.

Counselling

This is the first step in dealing with misbehaviour. Such counselling of a student by a teacher can be immediate and informal.

Class Detentions

Teachers may impose detentions if students fail to complete their work, or are inattentive or disruptive in class. The main purpose of the class detention is for the student and teacher to review the reason and solution for the student's misbehaviour.

Parent Contact

Parents or guardians need to be involved in the corrective discipline initiated by the teacher.

School Office's Role: Repeated misbehaviour in class, serious offences, and any breaking of general school rules are to be brought to the attention of the principal or vice-principal by means of a written report. The office has the following options in dealing with discipline.

Counselling

This first step could be used if the problem can be quickly resolved or if there is a misunderstanding between a student and a teacher.

Parent Contact

The office will contact the parents if there has been a serious infraction, or when a less serious infraction is repeated. Parents are also contacted by phone and letter if a student is accumulating too many office detentions.

Detentions

Office detentions can be assigned for lateness, truancy, breaking of general school rules, and major or repeated disruptions in class. Office detentions have precedence over all other school activities. A detention is intended to inconvenience the student and to deter him from future actions that might result in additional detentions.

Behaviour Log

If a student has repeatedly demonstrated inappropriate behaviour, his teachers will record their daily observations of his behaviour and performance in a three-day behaviour log. At the end of the three days, the recorded information is examined by the vice-principal, who then reviews it with the student, if necessary. A contract may be established that specifies the required behaviour and the consequences of suitable and non-suitable behaviour.

Financial Compensation

If a student damages school property, he will be required to pay for its repair or replacement. If a student denies involvement and is later found to be guilty, a suspension may also be added.

Withdrawal of Privileges

Unacceptable behaviour may result in a student's losing, for a specified length of time, his privilege in taking part in intramurals, school teams, clubs, and school trips. Students involved in these activities are expected to be positive role models in the school and the community.

Removal from Class

A student may temporarily lose the privilege of attending a specific class for failing to cooperate with the teacher.

A student may also lose the privilege of attending all his classes for an extended period of time. The principal may suspend a student for one to five days for showing disrespect to a teacher, verbal and physical abuse, major disruption, repeated office detentions or repeated smoking on school property.

Students are responsible for all work missed during a suspension, and will be allowed to complete tests or hand in assignments on the first day back from a suspension.

If, in spite of all the above measures, the student continues to demonstrate chronic disruption of classes, disrespect for teachers, a threat to students and teachers, or consumption or possession of drugs or alcohol at school, on buses, or at activities sponsored by the school, then the principal will suspend the student until the subsequent Board meeting. The Board will make the final decision about the expulsion. During the time of the expulsion, the student will not be permitted to be on school property or attend school functions without prior permission from the principal.

If a student is expelled by the Board, they cannot seek re-admission until the current and subsequent semester have been completed. Requests for readmission are reviewed by the Board.

18. Attendance

Regular and punctual attendance on the part of students is vital to the process of learning and essential for success in a course. If attendance is irregular, the student suffers a loss of experience that cannot be entirely regained. To increase the likelihood of students' successfully completing all of the courses, attendance

is checked on a regular basis as follows:

- a. If a student is reported absent from school and the parents have not called, the school will call home to confirm the reason for the absence.
- b. Skipping of classes during the school day will result in office detentions.
- c. If a student is absent for 8 to 10 days in any semester, the principal will contact the home. A further interview with the parents may also be arranged.
- d. At 15 absences, a student will be in jeopardy of losing his credits.

Parents or guardians are asked to inform the school before 9:15 a.m. why their son or daughter is absent. Studying for a test, completing an assignment, etc. is not considered a valid reason for being absent, and could result in a zero being assigned in any form of evaluation during the absence.

Students planning to be absent for more than three days for reasons other than illness are to have their parents contact the principal. Students are responsible for catching up on their work and making arrangements with the teachers to complete tests and assignments within one week of their return to school. Days of absence will be counted towards the maximum of 15 days that could place a student's credits in jeopardy.

If a student is ill and cannot write a final examination, his parents should immediately inform the school and obtain a medical certificate. The student may be given permission to write the exam at some other time within the exam week.

Punctuality is critical to the successful start of each class. Students are expected to be in their appropriate classrooms by the time the bell rings to start the class.

Students arriving late for school must sign in at the office. A note or a phone call from their parents is required to explain the reason for the lateness.

Students in Ontario are required to remain in secondary school until the age of eighteen or until they have obtained an OSSD.

19. Student Dress Code

Students are expected to reflect a Christian life-style in dress and appearance. They should be well groomed and wear neat and clean clothing. Modesty is an essential requirement. This means that clothing must not be distracting to others or sexually provocative and should be appropriate for a school setting. All students must wear the approved school shirts and sweaters with the school crest as outlined in the Parent Handbook.

20. Plagiarism Policy

Plagiarism is using others' ideas and words without clearly acknowledging the source of the information. Specifically, plagiarism includes

- a. copying published materials without giving credit;
- b. copying parts or all of another student's assignment or sharing answers via a calculator or other electronic devices;
- c. lending an assignment for another student to copy.

- d. using electronic translating tools
- e. purchasing essays

Whether this happens unintentionally or deliberately, these practices are unacceptable.

When the ideas of another are paraphrased or interpreted and are therefore presented without quotation marks, the source must nevertheless be fully and accurately identified. Each instructor who assigns a paper or report may direct students to a particular style for footnote and bibliographic documentation.

Teachers are to teach proper methods of documenting sources, particularly in Grade 9. Further suggestions to prevent plagiarism are detailed in the Teacher's Handbook.

Teachers will be diligent to detect incidents of cheating and plagiarism in order to maintain academic standards. Use of on-line sources, knowledge of the writing styles of their students, and careful reading of submitted material will be used to prevent academic dishonesty.

All incidents of plagiarism will be reported to the vice-principal in charge of discipline. In each case, parents will also be notified. The vice-principal, with input from the teacher, will determine the consequences. In general the following will be taken into consideration:

- a. The extent of the plagiarism (could range from carelessly missing a citation to deliberately trying to use the work of others and passing it off as one's own.)
- b. The grade level and maturity of the student
- c. The individual circumstances of the student.

A progression of penalties will adhere to the following guidelines:

- a. First Offence: An offense of a Grade 9 or 10 student will result in an opportunity to re-do the assignment, fixing plagiarism errors without any further academic penalty. An offense of a Grade 11 or 12 student will result in an opportunity to re-do the assignment. Academic penalties may be applied. Professional judgement will be used in determining where the offense lies on a continuum of offenses.
- b. Second Offence: A second offense will result in academic penalty of at least 10% and up to 100% and an opportunity to re-do the assignment, fixing plagiarism errors, may be given. These penalties will be made at the discretion of the teacher in consultation with the vice-principal. Professional judgement will be used in determining the extent of the penalties. In any case, the student will be expected to participate in a seminar hosted by the office in which the full implications of cheating will be made clear.
- c. Third Offence: A third offence could result in a suspension of the student. This suspension will be treated as a regular disciplinary infraction. Other penalties will be in line with second offence penalties described above.

21. Late and Missed Assignment Policy

Assignments are an integral part of student evaluation that gives students an opportunity to provide evidence of their achievement of course expectations within the time frame specified by the teacher. Students must take responsibility to complete assignments on time. Teachers must ensure that students have a clear

understanding of the assignment and have the prerequisite skills and knowledge that will ensure successful completion of the assignment. Parents should be contacted if students require assistance to complete their work on time.

As outlined in *Growing Success* (page 43), there are many strategies that teachers can and do use to help students submit assignments in a timely way.

- a. Teachers will provide students with their departmental late assignment policy in writing at the beginning of each semester.
- b. All assignments must be submitted by the stated deadline unless an extension has been granted.
- c. Students who have a legitimate absence on the day the assignment is due must submit their assignment without penalty when they return to school. This excludes students staying home with the purpose of completing assignments even if parental permission was granted.
- d. At the discretion of the teacher, deductions for overdue assignments can be made. This can include assigning a mark of zero to any assignment not received in a timely manner.
- e. Before receiving a final mark for the course, students must submit all assignments identified by the department as essential to the course. These assignments must be communicated in writing to the students as stated in point "a" above.

COURSE DESCRIPTIONS

The flow charts show the sequence in which courses are normally taken. A solid arrow (→) pointing to a particular course indicates that you are permitted to take this course only if you have completed the prerequisite, i.e., the course which precedes it in the given sequence. An intermittent arrow (---→) indicates that there is no such prerequisite. Further details are available on the school website (www.guidodebres.org) and the Ontario Ministry of Education website (<http://www.edu.gov.on.ca/eng/secondary.html>).

THE ARTS

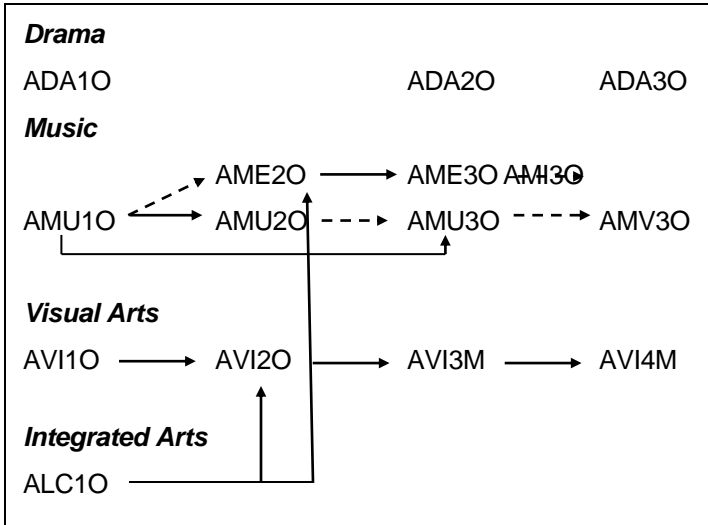

Drama

ADA10 – Drama

Grade 9, Open

This course provides opportunities for students to explore dramatic forms and techniques, using material from a wide range of sources and cultures. Students will use the elements of drama to examine situations and issues that are relevant to their lives. Students will create, perform, discuss, and analyse drama, and then reflect on the experiences to develop an understanding of themselves, the art form, and the world around them.

ADA20 – Drama

Grade 10, Open

This course provides opportunities for students to explore dramatic forms, conventions, and techniques. Students will explore a variety of dramatic sources from various cultures and representing a range of genres. Students will use the elements of drama in creating and communicating through dramatic works. Students will assume responsibility for decisions made in the creative and collaborative processes and will reflect on their experiences.

ADA20 and ADA30 are offered in alternate years.

Music Certificates Accepted for Credit

A maximum of one Grade 11 university/college preparation music credit may be awarded for the successful completion of one of the following: *Grade VII Practical and Intermediate Rudiments of the Royal Conservatory of Music, Toronto; Grade VII Practical and Grade III Theory of Conservatory Canada, London, Ontario; Collegial I Practical and Collegial I Theory of any conservatory of music in Quebec; Grade V Practical and Grade III Theory of Trinity College London, England; Grade VII Practical and Grade VI Theory of the Royal Schools of Music, London England.* The following course will apply: Music – External (Conservatory), AMX3M.

A maximum of one Grade 12 university/college preparation music credit may be awarded for the successful completion of one of the following: *Grade VIII Practical and Advanced Rudiments of the Royal Conservatory of Music, Toronto; Grade VIII Practical and Grade IV Theory of Conservatory Canada, London, Ontario; Collegial II Practical and Collegial II Theory of any conservatory of music in Quebec; Grade VI Practical and Grade IV Theory of Trinity College London, England; Grade VIII Practical and Grade VII Theory of the Royal Schools of Music, London England.* The following course will apply: Music—External (Conservatory), AMX4M.

Notes:

- The term practical refers to any musical instrument on which performance is examined. It includes voice (i.e., singing), but not speech arts.
- The mark credited to the student is calculated by averaging the marks that the student has earned in the practical component and in the rudiments or theory, as the case may be.

ADA30 – Drama

Grade 11, Open

This course requires students to engage in dramatic processes and the presentation of dramatic works, and emphasizes the application of drama skills in other contexts and opportunities. Students will interpret and present works in a variety of dramatic forms, create and script original works, and critically analyse the processes involved in producing drama works. Students will develop a variety of skills related to collaboration and the representation of drama works.

ADA20 and ADA30 are offered in alternate years.

Music

AMU10 – Music

Grade 9, Open (credit value: 0.5)

This course emphasizes the creation and performance of music at a level consistent with previous experience and is aimed at developing technique, sensitivity, and imagination. Students will develop musical literacy skills by using the creative and critical analysis processes in composition, performance, and a range of reflective and analytical activities. Students will develop an understanding of the conventions and elements of music and of safe practices related to music, and will develop a variety of skills transferable to other areas of their life.

AME20 – Music, Small Ensemble

Grade 10, Open

This course emphasizes the performance of instrumental music at an introductory level that strikes a balance between challenge and skill. Student learning will include participating in creative activities and listening perceptively. Students will also be required to develop a thorough understanding of the language of music.

AMU20 – Music

Grade 10, Open

This course emphasizes the creation and performance of music at a level consistent with previous experience. Students will develop musical literacy skills by using the creative and critical analysis processes in composition, performance, and a range of reflective and analytical activities. Students will develop their understanding of musical conventions, practices, and terminology and apply the elements of music in a range of activities. They will also explore the function of music in society with reference to the self, communities, and cultures.

AME30 – Music, Small Ensemble

Grade 11, Open

This course develops students' artistic knowledge and skills through the performance of music and the preparation of music productions. Independently and in groups, students will also plan and produce music productions, making use of appropriate technology. Students will develop techniques to perform required repertoire and skills necessary for achieving balance in performance. (*Prerequisite: AME20 or permission based on other qualifications.*)

AME30 and AMI30 are offered in alternate years.

AMI30 – Instrumental Music: Band

Grade 11, Open

This course develops students' artistic knowledge and instrumental skills through the study of music and the preparation of music for performance and accompaniment. Independently and in groups, students will also plan and rehearse productions, making use of appropriate technology. They will develop techniques to perform required repertoire and skills necessary for achieving balance in performances. (*Prerequisite: AME20 or permission based on other qualification.*)

AME30 and AMI30 are offered in alternate years.

AMU30 – Music

Grade 11, Open

This course develops students' musical literacy through performance and the preparation and presentation of music productions. Students will perform works at a level consistent with previous experience. Independently and collaboratively, students will use current technology and the creative and critical analysis processes to plan, produce, present, and market musical

productions. Students will respond to, reflect on, and analyse music from various genres and periods, and they will develop skills transferable to other aspects of their life and their careers.

AMU30 and AMV30 are offered in alternate years.

AMV30 – Music: Vocal/Choral

Grade 11, Open

This course develops students' artistic knowledge and vocal skills through the performance of music in various genres. Students will prepare, produce, and perform productions, making use of relevant technology. They will do so in small groups and individually.

AMU30 and AMV30 are offered in alternate years.

Visual Arts

AVI10 – Visual Art

Grade 9, Open (credit value: 0.5)

This course is exploratory in nature, offering an overview of visual arts as a foundation for further study. Students will become familiar with the elements and principles of design and the expressive qualities of various materials by using a range of media, processes, techniques, and styles. Students will use the creative and critical analysis processes and will interpret art within a personal, contemporary, and historical context.

AVI20 – Visual Arts

Grade 10, Open

This course enables students to develop their skills in producing and presenting art by introducing them to new ideas, materials, and processes for artistic exploration and experimentation. Students will apply the elements and principles of design when exploring the creative process. Students will use the critical analysis process to reflect on and interpret art within a personal, contemporary, and historical context.

AVI3M – Visual Arts

Grade 11, University/College Preparation

This course enables students to further develop their knowledge and skills in visual arts. Students will use the creative process to explore a wide range of themes through studio work that may include drawing, painting, sculpting, and printmaking, as well as the creation of collage, multimedia works, and works using emerging technologies. Students will use the critical analysis process when evaluating their own work and the work of others. The course may be delivered as a comprehensive program or through a program focused on a particular art form (e.g., photography, video, computer graphics, information design).

AVI4M – Visual Arts

Grade 12, University/College Preparation

This course focuses on enabling students to refine their use of the creative process when creating and presenting two- and three-dimensional art works using a variety of traditional and emerging media and technologies. Students will use the critical analysis process to deconstruct art works and explore connections between art and society. The studio program enables students to explore a range of materials, processes, and techniques that can be applied in their own art production. Students will also make connections between various works of art in personal, contemporary, historical, and cultural contexts.

Integrated Arts

ALC10 – Integrated Arts Grade 9, Open

This course integrates drama, music, and visual arts, giving students the opportunity to produce and present integrated art works created individually or collaboratively. Students will demonstrate innovation as they learn and apply concepts, styles, and conventions unique to the various arts and acquire skills that are transferable beyond the classroom. Students will use the creative process and responsible practices to explore solutions to integrated arts challenges.

BUSINESS AND COMPUTER STUDIES

Business Studies

BEP20

BAF3M
BDP3O

Information Technology

TEJ10

BTA30 → BTX4C
 → BTX4E

Business Studies

BEP20 – Launching and Leading a Business Grade 10, Open

This course introduces students to the world of business and what is required to be successful, ethical, and responsible in today's economy. Students will develop the knowledge and skills needed to be an entrepreneur who knows how to respond to local and global market opportunities. Throughout the course, students will explore and understand the responsibility of managing different functions of a business. This includes accounting, marketing, information and communication technology, financial management, human resources, and production.

BAF3M – Financial Accounting Fundamentals Grade 11, University/College Preparation

This course introduces students to the fundamental principles and procedures of accounting. Students will develop financial analysis and decision-making skills that will assist them in future studies and/or career opportunities in business. Students will acquire an understanding of accounting for a service and a merchandising business, computerized accounting, financial analysis, and ethics and current issues in accounting.

BDP3O – The Enterprising Person Grade 11, Open

This course examines the importance of enterprising employees in today's changing business environment. Students will learn about the skills and attributes of enterprising employees, the distinguishing features of their work environments, and the challenges and rewards of becoming an enterprising person. Students will also have an opportunity to demonstrate and develop enterprising skills by planning and organizing a school or community event.

Information Technology

TEJ10 - Exploring Computer Technology Grade 9, Open (credit value: 0.5)

This exploratory course introduces students to concepts and skills in computer technology, which encompasses computer systems, networking, interfacing, and programming, as well as electronics and robotics. Students will develop an awareness of related environmental and societal issues, and will begin to explore secondary and postsecondary pathways leading to careers in the field. (This course is normally offered to Grade 10 students).

BTA30 – Information Technology Applications in Business Grade 11, Open

This course prepares students for the digital environment. Using a hands-on approach, students will further develop information and communication technology skills through the use of common business software applications. The concept and operation of e-business will be explored, and students will design and create an e-business website. The skills developed in this course will prepare students for success in the workplace and/or postsecondary studies.

BTX4C—Information Technology in Business Grade 12, College Preparation

This course provides students with the opportunity to apply their information and communication technology skills while working in a team environment. Through a project-based approach, students will have opportunities to integrate common business software applications and apply multimedia techniques. Students will further develop their understanding of electronic business and e-commerce environments. The skills acquired in this course will prepare students for success in postsecondary studies and in their future careers.

BTX4E—Information Technology in Business Grade 12, Workplace Preparation

This course provides students with the opportunity to further develop essential workplace skills in information and communication technology while working in a team environment. Using a project-based approach, students will focus on integrating software applications and applying multimedia software features. Students will expand their understanding of electronic business and e-commerce environments and workplace ethics. This course will prepare students for a successful transition from secondary school to the workplace.

CANADIAN AND WORLD STUDIES

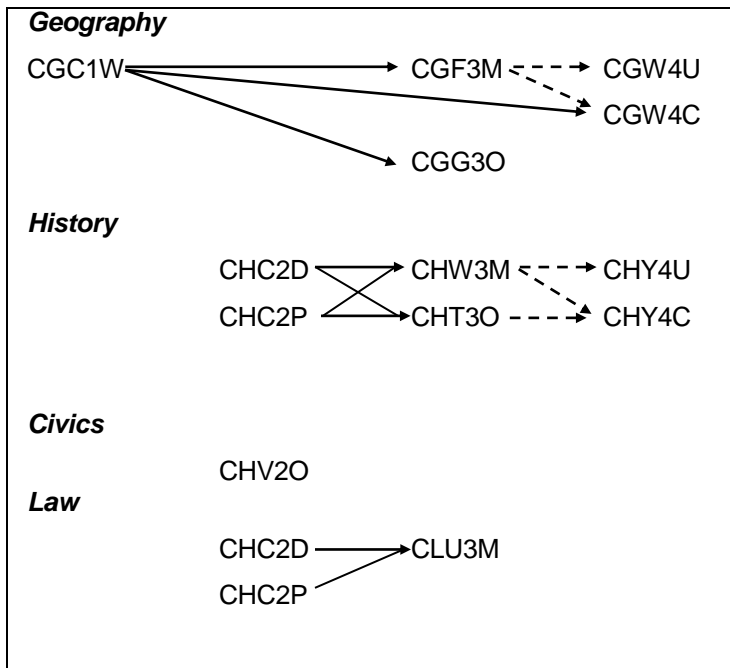

Geography

CGC1W – Exploring Canadian Geography

Grade 9, De-streamed

This course builds on learning in Grades 7 and 8 in geography. Students will explore relationships within and between Canada's natural and human systems and how they interconnect with other parts of the world. Students will also examine environmental and economic issues, and their impact related to topics such as natural resources and industries, careers, land use and responsible development, and sustainability. In addition, students will understand the connections that diverse communities and individuals have with the physical environment and each other throughout Canada, including First Nations, Métis, and Inuit perspectives. Students will apply geographic thinking, use the geographic inquiry process, and use geospatial technologies throughout their investigations.

CGG30 – Travel and Tourism: A Geographic Perspective

Grade 11, Open

This course focuses on issues related to travel and tourism within and between various regions of the world. Students will investigate unique environmental, sociocultural, economic, and political characteristics of selected world regions. They will explore travel patterns and trends as well as tensions related to tourism, and will predict future tourism destinations. Students will apply the concepts of geographic thinking and the geographic inquiry process, including spatial technologies, to investigate the impact of the travel industry on natural environments and human communities.

CGF3M – Forces of Nature: Physical Processes and Disasters

Grade 11, University/College Preparation

In this course, students will explore physical processes related to the earth's water, land, and air. They will investigate how these processes shape the planet's natural characteristics and affect human systems, how they are involved in the creation of natural disasters, and how they influence the impacts of human disasters. Throughout the course, students will apply the concepts of geographic thinking and the geographic inquiry process and use spatial technologies to analyse these processes, make predictions related to natural disasters, and assess ways of responding to them.

CGW4U – World Issues: A Geographic Analysis

Grade 12, University Preparation

In this course, students will address the challenge of creating a more sustainable and equitable world. They will explore issues involving a wide range of topics, including economic disparities, threats to the environment, globalization, human rights, and quality of life, and will analyse government policies, international agreements, and individual responsibilities relating to them. Students will apply the concepts of geographic thinking and the geographic inquiry process, including the use of spatial technologies, to investigate these complex issues and their impacts on natural and human communities around the world.

Prerequisite: Any university or university/college preparation course in Canadian and world studies, English, or social sciences and humanities.

CGW4C – A Geographic Analysis

Grade 12, College Preparation

This course explores many difficult challenges facing Canada and the world today – challenges such as unequal access to food, water, and energy; urbanization; globalization; and meeting the needs of a growing world population while ensuring the sustainability of the natural environment. Students will explore these and other world issues from environmental, social, economic, and political perspectives, while applying the concepts of geographic thinking, the geographic inquiry process, and spatial technologies to guide and support their investigations.

History

CHC2D – Canadian History since World War I

Grade 10, Academic

This course explores social, economic, and political developments and events and their impact on the lives of different individuals, groups, and communities, including First Nations, Métis, and Inuit individuals and communities, in Canada since 1914. Students will examine the role of conflict and cooperation in Canadian society, Canada's evolving role within the global community, and the impact of various individuals, organizations, and events on identities, citizenship, and heritage in Canada. Students will develop an understanding of some of the political developments and government policies that have had a lasting impact on First Nations, Métis, and Inuit individuals and communities. They will develop their ability to apply the concepts of historical thinking and the historical inquiry process, including the interpretation and analysis of evidence, when investigating key issues and events in Canadian history since 1914.

CHC2P – Canadian History Since World War I
Grade 10, Applied

This course focuses on the social context of historical developments and events and how they have affected the lives of people in Canada, including First Nations, Métis, and Inuit individuals and communities, since 1914. Students will explore interactions between various communities in Canada as well as contributions of individuals and groups to heritage and identities in Canada. Students will develop an understanding of some key political developments and government policies that have had an impact on First Nations, Métis, and Inuit individuals and communities. They will develop their ability to apply the concepts of historical thinking and the historical inquiry process, including the interpretation and analysis of evidence, when investigating the continuing relevance of historical developments and how they have helped shape communities in present-day Canada.

CHW3M – World History to the End of the Fifteenth Century
Grade 11, University/College Preparation

This course explores the history of various societies and civilizations around the world, from earliest times to around 1500 CE. Students will investigate a range of factors that contributed to the rise, success, and decline of various ancient and pre-modern societies throughout the world and will examine life in and the cultural and political legacy of these societies. Students will extend their ability to apply the concepts of historical thinking and the historical inquiry process, including the interpretation and analysis of evidence, when investigating social, political, and economic structures and historical forces at work in various societies and in different historical eras.

CHT3O – World History since 1900: Global and Regional Interactions

Grade 11, Open

This course focuses on major developments in world history from 1900 to the present. Students will explore the causes and consequences of global and regional conflicts, the impact of significant individuals and social movements, and the effects of social, economic, and political developments around the world. Students will extend their ability to apply the concepts of historical thinking and the historical inquiry process, including the interpretation and analysis of evidence, when investigating interactions within and between nations and other historical developments and events, including those that continue to affect people in various parts of the world.

CHY4U – World History since the Fifteenth Century
Grade 12, University Preparation

This course traces major developments and events in world history since approximately 1450. Students will explore social, economic, and political changes, the historical roots of contemporary issues, and the role of conflict and cooperation in global interrelationships. They will extend their ability to apply the concepts of historical thinking and the historical inquiry process, including the interpretation and analysis of evidence, as they investigate key issues and assess societal progress or decline in world history.

Prerequisite: Any university or university/college preparation course in Canadian and world studies, English, or social sciences and humanities.

CHY4C – World History since the Fifteenth Century
Grade 12, College Preparation

This course explores key developments and events in world history since approximately 1450, with a focus on interactions within and between various regions. Students will examine social, economic, and political developments and how they have affected

different peoples. Students will extend their ability to apply the concepts of historical thinking and the historical inquiry process, including the interpretation and analysis of evidence, when investigating key turning points in world history and historical forces that have shaped our world.

Prerequisite: Any university, university/college or college preparation course in Canadian and world studies, English, or social sciences and humanities.

LVV4U—Classical Civilization. See CLASSICAL STUDIES.

Civics

CHV2O – Civics and Citizenship

Grade 10, Open(credit value: 0.5)

This course explores rights and responsibilities associated with being an active citizen in a democratic society. Students will explore issues of civic importance and the influence of social media, while developing their understanding of the role of civic engagement and of political processes in the local, national, and/or global community. Students will apply the concepts of political thinking and the political inquiry process to investigate, and express informed opinions about, a range of political issues and developments that are both of significance in today's world and of personal interest to them. This course also includes learning on digital literacy and critical-thinking skills, the mechanisms of government, Indigenous governance systems and structures, the historical foundations of the rights and freedoms we enjoy in Canada, ways in which government policy affects individuals' lives and the economy, and ways for students to serve their communities.

Law

CLU3M – Understanding Canadian Law

Grade 11, University/College Preparation

This course explores Canadian law, with a focus on legal issues that are relevant to the lives of people in Canada. Students will gain an understanding of laws relating to rights and freedoms in Canada; our legal system; and family, contract, employment, tort, and criminal law. Students will develop legal reasoning skills and will apply the concepts of legal thinking and the legal studies inquiry process when investigating a range of legal issues and formulating and communicating informed opinions about them.

Prerequisite: Canadian History since World War I, Grade 10, Academic or Applied

ENGLISH

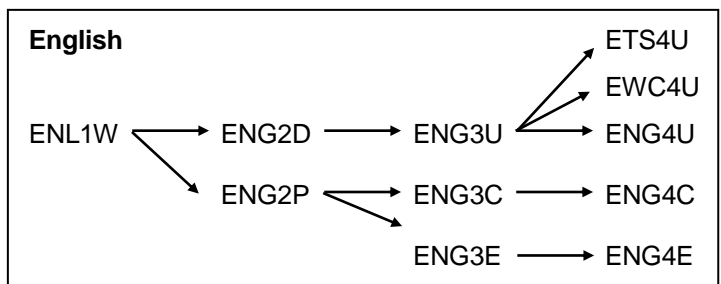

ENL1W – English

Grade 9, Academic

This course enables students to continue to develop and consolidate the foundational knowledge and skills that they need

for reading, writing, and oral and visual communication. Throughout the course, students will continue to enhance their media literacy and critical literacy skills, and to develop and apply transferable skills, including digital literacy. Students will also make connections to their lived experiences and to society and increase their understanding of the importance of language and literacy across the curriculum.

ENG2D – English

Grade 10, Academic

This course is designed to extend the range of oral communication, reading, writing, and media literacy skills that students need for success in their secondary school academic programs and in their daily lives. Students will analyse literary texts from contemporary and historical periods, interpret and evaluate informational and graphic texts, and create oral, written, and media texts in a variety of forms. An important focus will be on the selective use of strategies that contribute to effective communication. This course is intended to prepare students for the compulsory Grade 11 university or college preparation course.

ENG2P – English

Grade 10, Applied

This course is designed to extend the range of oral communication, reading, writing, and media literacy skills that students need for success in secondary school and daily life. Students will study and create a variety of informational, literary, and graphic texts. An important focus will be on the consolidation of strategies and processes that help students interpret texts and communicate clearly and effectively. This course is intended to prepare students for the compulsory Grade 11 college or workplace preparation course.

ENG3U – English

Grade 11, University Preparation

This course emphasizes the development of literacy, communication, and critical and creative thinking skills necessary for success in academic and daily life. Students will analyse challenging literary texts from various periods, countries, and cultures, as well as a range of informational and graphic texts, and create oral, written, and media texts in a variety of forms. An important focus will be on using language with precision and clarity and incorporating stylistic devices appropriately and effectively. The course is intended to prepare students for the compulsory Grade 12 university or college preparation course.

ENG3C – English

Grade 11, College Preparation

This course emphasizes the development of literacy, communication, and critical and creative thinking skills necessary for success in academic and daily life. Students will study the content, form, and style of a variety of informational and graphic texts, as well as literary texts from Canada and other countries, and create oral, written, and media texts in a variety of forms for practical and academic purposes. An important focus will be on using language with precision and clarity. The course is intended to prepare students for the compulsory Grade 12 college preparation course.

ENG3E – English

Grade 11, Workplace Preparation

This course emphasizes the development of literacy, communication, and critical and creative thinking skills necessary for success in the workplace and in daily life. Students will study the content, form, and style of a variety of contemporary informational, graphic, and literary texts; and create oral, written, and media texts in a variety of forms for practical purposes. An

important focus will be on using language clearly and accurately in a variety of formal and informal contexts. The course is intended to prepare students for the compulsory Grade 12 workplace preparation course.

ENG4U – English

Grade 12, University Preparation

This course emphasizes the consolidation of the literacy, communication, and critical and creative thinking skills necessary for success in academic and daily life. Students will analyse a range of challenging literary texts from various periods, countries, and cultures; interpret and evaluate informational and graphic texts; and create oral, written, and media texts in a variety of forms. An important focus will be on using academic language coherently and confidently, selecting the reading strategies best suited to particular texts and particular purposes for reading, and developing greater control in writing. The course is intended to prepare students for university, college, or the workplace.

EWC4U – The Writer's Craft

Grade 12, University Preparation

This course emphasizes knowledge and skills related to the craft of writing. Students will analyse models of effective writing; use a workshop approach to produce a range of works; identify and use techniques required for specialized forms of writing; and identify effective ways to improve the quality of their writing. They will also complete a major paper as part of a creative or analytical independent study project and investigate opportunities for publication and for writing careers. *(This is an optional course. It may be taken in addition to ENG4U but not instead of it. ENG3U is the prerequisite.)*

EWC4U and ETS4U are offered in alternate years.

ETS4U – Studies in Literature

Grade 12, University Preparation

This course is for students with a special interest in literature and literary criticism. The course may focus on themes, genres, time periods, or countries. Students will analyse a range of forms and stylistic elements of literary texts and respond personally, critically, and creatively to them. They will also assess critical interpretations, write analytical essays, and complete an independent study project. *(This is an optional course. It may be taken in addition to ENG4U but not instead of it. ENG3U is the prerequisite.)*

EWC4U and ETS4U are offered in alternate years.

ENG4C – English

Grade 12, College Preparation

This course emphasizes the consolidation of literacy, communication, and critical and creative thinking skills necessary for success in academic and daily life. Students will analyse a variety of informational and graphic texts, as well as literary texts from various countries and cultures, and create oral, written, and media texts in a variety of forms for practical and academic purposes. An important focus will be on using language with precision and clarity and developing greater control in writing. The course is intended to prepare students for college or the workplace.

ENG4E – English

Grade 12, Workplace Preparation

This course emphasizes the consolidation of literacy, communication, and critical and creative thinking skills necessary for success in the workplace and in daily life. Students will analyse informational, graphic, and literary texts and create oral, written, and media texts in a variety of forms for workplace-related and practical purposes. An important focus will be on using language accurately and organizing ideas and information coherently. The course is intended to prepare students for the workplace and active citizenship.

GUIDANCE AND CAREER EDUCATION

Guidance and Career Education

GLC20

GPP30

GLC20 – Career Studies

Grade 10, Open (credit value: 0.5)

This course gives students the opportunity to develop the skills, knowledge, and habits that will support them in their education and career/life planning. Students will learn about global work trends, and seek opportunities within the school and community to expand and strengthen their transferable skills and their ability to adapt to the changing world of work. On the basis of exploration, reflective practice, and decision-making processes, students will make connections between their skills, interests, and values and their postsecondary options, whether in apprenticeship training, college, community living, university, or the workplace. They will set goals and create a plan for their first postsecondary year. As part of their preparation for the future, they will learn about personal financial management – including the variety of saving and borrowing tools available to them and how to use them to their advantage – and develop a budget for their first year after secondary school.

GPP30 – Leadership and Peer Support

Grade 11, Open

This course prepares students to act in leadership and peer support roles. They will design and implement a plan for contributing to their school and/or community; develop skills in communication, interpersonal relations, teamwork, and conflict management; and apply those skills in leadership and/or peer support roles – for example, as a student council member or a peer tutor. Students will examine group dynamics and learn the value of diversity within groups and communities.

FRENCH

French

FSF1D → FSF2D → FSF3U → FSF4U

FSF10

FSF1D – Core French

Grade 9, Academic

This course provides opportunities for students to communicate and interact in French with increasing independence, with a focus on familiar topics related to their daily lives. Students will develop their skills in listening, speaking, reading, and writing by using language learning strategies introduced in the elementary Core French program, and will apply creative and critical thinking skills in various ways. They will also enhance their understanding and appreciation of diverse French-speaking communities, and will develop skills necessary for lifelong language learning.

Prerequisite: Minimum of 600 hours of French instruction, or equivalent

FSF10 – Core French

Grade 9, Open

This is an introductory course for students who have little or no knowledge of French or who have not accumulated the minimum of 600 hours of elementary Core French instruction. Students will begin to understand and speak French in guided and structured interactive settings, and will develop fundamental skills in listening, speaking, reading, and writing through discussing issues and situations that are relevant to their daily lives. Throughout the course, students will develop their awareness of diverse French-speaking communities in Canada and acquire an understanding and appreciation of these communities. They will also develop a variety of skills necessary for lifelong language learning.

FSF2D – Core French

Grade 10, Academic

This course provides opportunities for students to communicate in French about personally relevant, familiar, and academic topics in real-life situations with increasing independence. Students will exchange information, ideas, and opinions with others in guided and increasingly spontaneous spoken interactions. Students will develop their skills in listening, speaking, reading, and writing through the selective use of strategies that contribute to effective communication. They will also increase their understanding and appreciation of diverse French-speaking communities, and will develop skills necessary for lifelong language learning.

FSF3U – Core French

Grade 11, University

This course offers students extended opportunities to speak and interact in real-life situations in French with greater independence. Students will develop their listening, speaking, reading, and writing skills, as well as their creative and critical thinking skills, through responding to and exploring a variety of oral and written texts. They will also broaden their understanding and appreciation of diverse French-speaking communities, and will develop skills necessary for lifelong language learning.

FSF4U – Core French

Grade 12, University

This course provides extensive opportunities for students to speak and interact in French independently. Students will develop their listening, speaking, reading, and writing skills, apply language learning strategies in a wide variety of real-life situations, and develop their creative and critical thinking skills through responding to and interacting with a variety of oral and written texts. They will also enrich their understanding and appreciation of diverse French-speaking communities, and will develop skills necessary for lifelong language learning. *(Recommended prerequisite: a minimum of 65% in FSF3U.)*

RELIGIOUS STUDIES

Religious Studies

HRE13 → HRE23 → HRE33 - - - → HRE43
HRT3M

HRT3M – World Religions and Belief Traditions: Perspectives, Issues, and Challenges

Grade 11, University/College Preparation

This course provides students with opportunities to explore various world religions and belief traditions. Students will develop knowledge of the terms and concepts relevant to this area of study, will examine the ways in which religions and belief traditions meet various human needs, and will learn about the relationship between belief and action. They will examine sacred writings and teachings, consider how concepts of time and place influence different religions and belief traditions, and develop research and inquiry skills related to the study of human expressions of belief.

The following are locally developed courses:

HRE13 – Religious Studies

Grade 9, Open(credit value: 0.5)

In this course, archaeology is used to aid the study of the Old Testament by illustrating and illuminating the cultural background of the Bible lands. Covering an area from Mesopotamia to Egypt and spanning the time period from Creation to the Hellenistic period, it highlights the themes of the Old Testament. Creation, the Fall, and the Flood are discussed in their biblical and cultural context. A study of some of the prophetic books of the Bible will contribute to an understanding of the culture of the Assyrians, Persians, and the Temple Period.

HRE23 – Religious Studies

Grade 10, Open(credit value: 0.5)

The theme of the course is the growth of the early Christian church within the context of Greek, Roman, and Palestinian influences. The Gospel of Matthew will be used to illustrate the work of Christ. A comparison with the other gospels will concentrate on showing the distinctive characteristics of each. The study of the Book of Acts will focus on the spread of the gospel and the founding of the early church. The Letter to the Galatians will be used to show how Paul gave direction to the early church in teaching the essential importance of the doctrine of justification by faith. The history of the early church will be traced as far as the formulation of the ecumenical creeds.

HRE33 – Religious Studies

Grade 11 or 12, Open

In this course students will integrate the following: developing Bible study skills, increasing their knowledge of Scripture, and examining issues related to the interpretation of Scripture. In this connection the focus will be on the Letter to the Romans and Ecclesiastes. Other areas of concentration are the history of the church since the nineteenth century, the defence of the Reformed faith in confrontation with such world religions as Islam and Buddhism, an examination of contemporary issues from a Biblical perspective, as well as an overview of the Three Forms of Unity, with special emphasis on the Canons of Dort.

HRE43 – Religious Studies

Grade 11 or 12, Open

In this course the emphasis will be placed on an in-depth study of the unity of the Bible. Special attention will be paid to recurring

themes, concepts, symbols, and metaphors. Students will trace the covenant of love throughout the Scriptures, study selections from the Psalms and from Revelation in relation to other parts of the Bible, and focus on central themes of the Reformation as expression of what is taught in the Scriptures as a whole.

PHILOSOPHY

Philosophy

HZT4U

HZT4U – Philosophy: Questions and Theories

Grade 12, University Preparation

This course enables students to acquire an understanding of the nature of philosophy and philosophical reasoning skills and to develop and apply their knowledge and skills while exploring specialized branches of philosophy (the course will cover at least three of the following branches: metaphysics, ethics, epistemology, philosophy of science, social and political philosophy, aesthetics). Students will develop critical thinking and philosophical reasoning skills as they formulate and evaluate arguments related to a variety of philosophical questions and theories. They will also develop research and inquiry skills related to the study and practice of philosophy.

(Prerequisite: Any university or university/college preparation course in social science and humanities, English or Canadian and world studies.)

CLASSICAL STUDIES

Classical Civilization

LVV4U

LVV4U—Classical Civilization

Grade 12, University Preparation

This course introduces students to the rich cultural legacy of the classical world. Students will investigate aspects of classical culture, including mythology, literature, art, architecture, philosophy, science, and technology, as well as elements of the ancient Greek and Latin languages. Students will develop creative and critical thinking skills through exploring and responding to works by classical authors in English translation and examining material culture brought to light through archaeology. They will also increase their communication and research skills by working both collaboratively and independently, and will acquire an understanding and appreciation of the interconnectedness of ancient and modern societies.

Prerequisite: English, Grade 10, Academic

MATHEMATICS

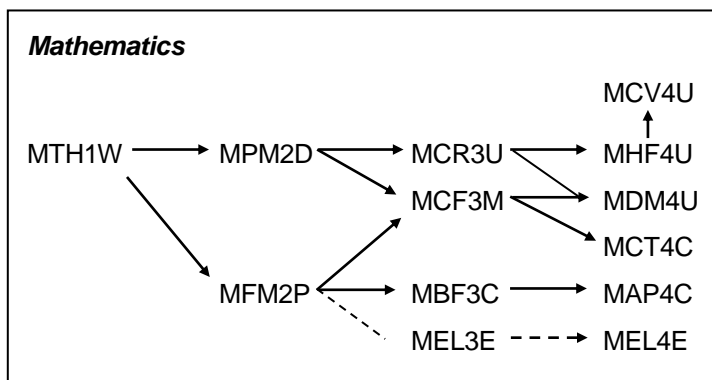

MTH1W – Mathematics

Grade 9

This course enables students to consolidate, and continue to develop, an understanding of mathematical concepts related to number sense and operations, algebra, measurement, geometry, data, probability, and financial literacy. Students will use mathematical processes, mathematical modelling, and coding to make sense of the mathematics they are learning and to apply their understanding to culturally responsive and relevant real-world situations. Students will continue to enhance their mathematical reasoning skills, including proportional reasoning, spatial reasoning, and algebraic reasoning, as they solve problems and communicate their thinking.

MPM2D – Principles of Mathematics

Grade 10, Academic

This course enables students to broaden their understanding of relationships and extend their problem-solving and algebraic skills through investigation, the effective use of technology, and abstract reasoning. Students will explore quadratic relations and their applications; solve and apply linear systems; verify properties of geometric figures using analytic geometry; and investigate the trigonometry of right and acute triangles. Students will reason mathematically and communicate their thinking as they solve multi-step problems. (Recommended prerequisite: a minimum of 60% in MTH1W.)

MFM2P – Foundations of Mathematics

Grade 10, Applied

This course enables students to consolidate their understanding of linear relations and extend their problem-solving and algebraic skills through investigation, the effective use of technology, and hands-on activities. Students will develop and graph equations in analytic geometry; solve and apply linear systems, using real-life examples; and explore and interpret graphs of quadratic relations. Students will investigate similar triangles, the trigonometry of right triangles, and the measurement of three-dimensional figures. Students will consolidate their mathematical skills as they solve problems and communicate their thinking.

MCR3U – Functions

Grade 11, University Preparation

This course introduces the mathematical concept of the function by extending students' experiences with linear and quadratic relations. Students will investigate properties of discrete and continuous functions, including trigonometric and exponential functions; represent functions numerically, algebraically, and graphically; solve problems involving applications of functions; investigate inverse functions; and develop facility in determining equivalent algebraic expressions. Students will reason mathematically and communicate their thinking as they solve multi-step problems. (Recommended prerequisite: a minimum of 65% in MPM2D.)

MCF3M – Functions and Applications

Grade 11, University/College Preparation

This course introduces basic features of the function by extending students' experiences with quadratic relations. It focuses on quadratic, trigonometric, and exponential functions and their use in modelling real-world situations. Students will represent functions numerically, graphically, and algebraically; simplify expressions; solve equations; and solve problems relating to applications. Students will reason mathematically and communicate their thinking as they solve multi-step problems. (Prerequisite: MPM2D or MFM2P.)

MBF3C – Foundations for College Mathematics

Grade 11, College Preparation

This course enables students to broaden their understanding of mathematics as a problem-solving tool in the real world. Students will extend their understanding of quadratic relations; investigate situations involving exponential growth; solve problems involving compound interest; solve financial problems connected with vehicle ownership; develop their ability to reason by collecting, analysing, and evaluating data involving one variable; connect probability and statistics; and solve problems in geometry and trigonometry. Students will consolidate their mathematical skills as they solve problems and communicate their thinking.

MEL3E – Mathematics for Work and Everyday Life

Grade 11, Workplace Preparation

This course enables students to broaden their understanding of mathematics as it is applied in the workplace and daily life. Students will solve problems associated with earning money, paying taxes, and making purchases; apply calculations of simple and compound interest in saving, investing, and borrowing; and calculate the costs of transportation and travel in a variety of situations. Students will consolidate their mathematical skills as they solve problems and communicate their thinking.

MEL3E and MEL4E are offered in alternate years.

MHF4U – Advanced Functions

Grade 12, University Preparation

This course extends students' experience with functions. Students will investigate the properties of polynomial, rational, logarithmic, and trigonometric functions; develop techniques for combining functions; broaden their understanding of rates of change; and develop facility in applying these concepts and skills. Students will also refine their use of the mathematical processes necessary for success in senior mathematics. This course is intended both for students taking the Calculus and Vectors course as a prerequisite for a university program and for those wishing to consolidate their understanding of mathematics before proceeding to any one of a variety of university programs.

MCV4U – Calculus and Vectors

Grade 12, University Preparation

This course builds on students' previous experience with functions and their developing understanding of rates of change. Students will solve problems involving geometric and algebraic representations of vectors and representations of lines and planes in three-dimensional space; broaden their understanding of rates of change to include the derivatives of polynomial, sinusoidal, exponential, rational, and radical functions; and apply these concepts and skills to the modelling of real-world relationships. Students will also refine their use of the mathematical processes necessary for success in senior mathematics. This course is intended for students who choose to pursue careers in fields such as science, engineering, economics, and some areas of business, including those students who will be required to take a university-level calculus, linear algebra, or physics course.

MDM4U – Mathematics of Data Management

Grade 12, University Preparation

This course broadens students' understanding of mathematics as it relates to managing data. Students will apply methods for organizing and analysing large amounts of information; solve problems involving probability and statistics; and carry out a culminating investigation that integrates statistical concepts and skills. Students will also refine their use of the mathematical processes necessary for success in senior mathematics. Students planning to enter university programs in business, the social sciences, and the humanities will find this course of particular interest.

MAP4C – Foundations for College Mathematics

Grade 12, College Preparation

This course enables students to broaden their understanding of real-world applications of mathematics. Students will analyse data using statistical methods; solve problems involving applications of geometry and trigonometry; solve financial problems connected with annuities, budgets, and renting or owning accommodation; simplify expressions; and solve equations. Students will reason mathematically and communicate their thinking as they solve multi-step problems. This course prepares students for college programs in areas such as business, health sciences, and human services, and for certain skilled trades.

MCT4C – Mathematics for College Technology

Grade 12, College Preparation

This course enables students to extend their knowledge of functions. Students will investigate and apply properties of polynomial, exponential, and trigonometric functions; continue to represent functions numerically, graphically, and algebraically; develop facility in simplifying expressions and solving equations; and solve problems that address applications of algebra, trigonometry, vectors, and geometry. Students will reason mathematically and communicate their thinking as they solve multi-step problems. (This course prepares students for a variety of college technology programs. Prerequisite: MCF3M.)

MEL4E – Mathematics for Work and Everyday Life

Grade 12 Workplace Preparation

This course enables students to broaden their understanding of mathematics as it is applied in the workplace and daily life. Students will investigate questions involving the use of statistics; apply the concept of probability to solve problems involving familiar situations; investigate accommodation costs, create household budgets, and prepare a personal income tax return; use proportional reasoning; estimate and measure; and apply

geometric concepts to create designs. Students will consolidate their mathematical skills as they solve problems and communicate their thinking.

MEL3E and MEL4E are offered in alternate years.

HEALTH AND PHYSICAL EDUCATION

Health and Physical Education

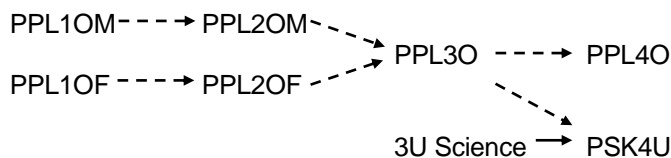

PPL10F – Healthy Active Living Education

Grade 9, Open (Girls)

PPL10M – Healthy Active Living Education

Grade 9, Open (Boys)

This course equips students with the knowledge and skills they need to make healthy choices now and lead healthy, active lives in the future. Through participation in a wide range of physical activities, students develop knowledge and skills related to movement competence and personal fitness that provide a foundation for active living. Students also acquire an understanding of the factors and skills that contribute to healthy development and learn how their own well-being is affected by, and affects, the world around them. Students build their sense of self, learn to interact positively with others, and develop their ability to think critically and creatively.

PPL20F – Healthy Active Living Education

Grade 10, Open (Girls)

PPL20M – Healthy Active Living Education

Grade 10, Open (Boys)

(credit value: 0.5)

This course enables students to further develop the knowledge and skills they need to make healthy choices now and lead healthy, active lives in the future. Through participation in a wide range of physical activities, students develop knowledge and skills related to movement competence and personal fitness that provide a foundation for active living. Students also acquire an understanding of the factors and skills that contribute to healthy development and learn how their own well-being is affected by, and affects, the world around them. Students build their sense of self, learn to interact positively with others, and develop their ability to think critically and creatively.

PPL30 – Healthy Active Living Education

Grade 11, Open (Co-ed)

This course enables students to further develop the knowledge and skills they need to make healthy choices now and lead healthy, active lives in the future. Through participation in a wide range of physical activities and exposure to a broader range of activity settings, students enhance their movement competence, personal fitness, and confidence. Students also acquire an understanding of the factors and skills that contribute to healthy development and learn how their own well-being is affected by, and affects, the world around them. Students build their sense of self, learn to interact positively with others, and develop their ability to think critically and creatively.

PPL40 – Healthy Active Living

Grade 12, Open (Co-ed)

This course enables students to further develop the knowledge and skills they need to make healthy choices. It places special emphasis on how students can maintain the habits of healthy, active living throughout their lives as they make the transition to adulthood and independent living. Through participation in a wide range of physical activities in a variety of settings, students can enhance their movement competence, personal fitness, and confidence. Students also acquire an understanding of the factors and skills that contribute to healthy development and learn how their own well-being is affected by, and affects, the world around them. Students build their sense of self, learn to interact positively with others, and develop their ability to think critically and creatively.

PSK4U – Introductory Kinesiology

Grade 12, University Preparation

This course focuses on the study of human movement and of systems, factors, and principles involved in human development. Students will learn about the effects of physical activity on health and performance, the evolution of physical activity and sport, and the physiological, psychological, and social factors that influence an individual's participation in physical activity and sport. The course prepares students for university programs in physical education and health, kinesiology, health sciences, health studies, recreation, and sports administration.

SCIENCE

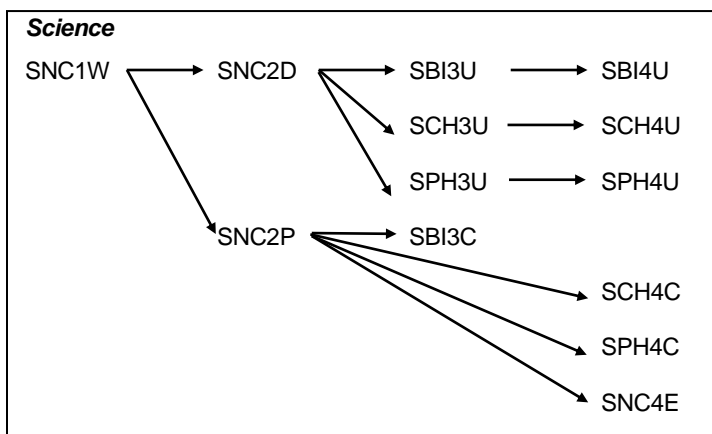

Science

SNC1W – Science

Grade 9

This course enables students to develop their understanding of concepts related to biology, chemistry, physics, and Earth and space science, and to relate science to technology, society, and the environment. Throughout the course, students will develop and refine their STEM skills as they use scientific research, scientific experimentation, and engineering design processes to investigate concepts and apply their knowledge in situations that are relevant to their lives and communities. Students will continue to develop transferable skills as they become scientifically literate global citizens.

SNC2D – Science

Grade 10, Academic

This course enables students to enhance their understanding of concepts in biology, chemistry, earth and space science, and physics, and of the interrelationships between science, technology, society, and the environment. Students are also given opportunities to further develop their scientific investigation skills. Students will plan and conduct investigations and develop their understanding of scientific theories related to the connections between cells and systems in animals and plants; chemical reactions, with a particular focus on acid-base reactions; forces that affect climate and climate change; and the interaction of light and matter.

SNC2P – Science

Grade 10, Applied

This course enables students to develop a deeper understanding of concepts in biology, chemistry, earth and space science, and physics, and to apply their knowledge of science in real-world situations. Students are given opportunities to develop further practical skills in scientific investigation. Students will plan and conduct investigations into everyday problems and issues related to human cells and body systems; chemical reactions; factors affecting climate change; and the interaction of light and matter.

SNC4E – Science

Grade 12, Workplace Preparation

This course provides students with fundamental science knowledge and workplace skills needed to prepare them for success beyond secondary school. Students will explore hazards in the workplace, chemicals in consumer products, disease and its prevention, electricity at home and at work, and nutritional science. Emphasis is placed on current topics in science and relevant, practical activities that develop students' literacy and mathematical literacy skills and enhance their scientific literacy. *(Prerequisite: SNC2P)*

Biology

SBI3U – Biology

Grade 11, University Preparation

This course furthers students' understanding of the processes that occur in biological systems. Students will study theory and conduct investigations in the areas of biodiversity; evolution; genetic processes; the structure and function of animals; and the anatomy, growth, and function of plants. The course focuses on the theoretical aspects of the topics under study, and helps students refine skills related to scientific investigation.

SBI3C – Biology

Grade 11, College Preparation

This course focuses on the processes that occur in biological systems. Students will learn concepts and theories as they conduct investigations in the areas of cellular biology, microbiology, genetics, the anatomy of mammals, and the structure of plants and their role in the natural environment. Emphasis will be placed on the practical application of concepts, and on the skills needed for further study in various branches of the life sciences and related fields.

SBI4U – Biology

Grade 12, University Preparation

This course provides students with the opportunity for in-depth study of the concepts and processes that occur in biological systems. Students will study theory and conduct investigations in the areas of biochemistry, metabolic processes, molecular genetics, homeostasis, and population dynamics. Emphasis will be placed on the achievement of detailed knowledge and the refinement of skills needed for further study in various branches of the life sciences and related fields. *(Recommended prerequisite: SCH3U– Chemistry)*

Chemistry

SCH3U – Chemistry

Grade 11, University Preparation

This course enables students to deepen their understanding of chemistry through the study of the properties of chemicals and chemical bonds; chemical reactions and quantitative relationships in those reactions; solutions and solubility; and atmospheric chemistry and the behaviour of gases. Students will further develop their analytical skills and investigate the qualitative and quantitative properties of matter, as well as the impact of some common chemical reactions on society and the environment.

SCH4U – Chemistry

Grade 12, University Preparation

This course enables students to deepen their understanding of chemistry through the study of organic chemistry, the structure and properties of matter, energy changes and rates of reaction, equilibrium in chemical systems, and electrochemistry. Students will further develop their problem-solving and investigation skills as they investigate chemical processes, and will refine their ability to communicate scientific information. Emphasis will be placed on the importance of chemistry in everyday life and on evaluating the impact of chemical technology on the environment.

SCH4C – Chemistry

Grade 12, College Preparation

This course enables students to develop an understanding of chemistry through the study of matter and qualitative analysis, organic chemistry, electrochemistry, chemical calculations, and chemistry as it relates to the quality of the environment. Students will use a variety of laboratory techniques, develop skills in data collection and scientific analysis, and communicate scientific information using appropriate terminology. Emphasis will be placed on the role of chemistry in daily life and the effects of technological applications and processes on society and the environment.

Physics

SPH3U – Physics

Grade 11, University Preparation

This course develops students' understanding of the basic concepts of physics. Students will explore kinematics, with an emphasis on linear motion; different kinds of forces; energy transformations; the properties of mechanical waves and sound; and electricity and magnetism. They will enhance their scientific investigation skills as they test laws of physics. In addition, they will analyse the interrelationships between physics and technology, and consider the impact of technological applications of physics on society and the environment.

SPH4U – Physics

Grade 12, University Preparation

This course enables students to deepen their understanding of physics concepts and theories. Students will continue their exploration of energy transformations and the forces that affect motion, and will investigate electrical, gravitational, and magnetic fields and electromagnetic radiation. Students will also explore the wave nature of light, quantum mechanics, and special relativity. They will further develop their scientific investigation skills, learning, for example, how to analyse, qualitatively and quantitatively, data related to a variety of physics concepts and principles. Students will also consider the impact of technological applications of physics on society and the environment.

SPH4C – Physics

Grade 12, College Preparation

This course develops students' understanding of the basic concepts of physics. Students will explore these concepts with respect to motion; mechanical, electrical, electromagnetic, energy transformation, hydraulic, and pneumatic systems; and the operation of commonly used tools and machines. They will develop their scientific investigation skills as they test laws of physics and solve both assigned problems and those emerging from their investigations. Students will also consider the impact of technological applications of physics on society and the environment.

TECHNOLOGICAL EDUCATION

Technology

Grade 9:	TAS1O	
Grade 10:	TCJ1O	
Grade 11/12:	TTJ2O	TWJ3E
	THJ1O	TCJ3C

TAS1O – Technology and the Skilled Trades

Grade 9, Open

This hands-on course enables students to further explore the engineering design process and develop other technological knowledge and skills introduced in earlier grades. Students will design and safely create prototypes, products, and/or services, working with tools and technologies from various industries. As students develop their projects to address real-life problems, they will apply technological concepts such as precision measurement,

as well as health and safety standards. Students will begin to explore job skills programs and education and training pathways, including skilled trades, that can lead to a variety of careers.

TCJ10 – Exploring Construction Technology

Grade 9, Open

This exploratory course introduces students to concepts and skills in construction technology, which encompasses plumbing, electrical and network wiring, masonry, heating/ cooling, carpentry, and woodworking. Students will develop an awareness of related environmental and societal issues, and will begin to explore secondary and postsecondary pathways leading to careers in the field. *(This course is normally offered in Grade 10).*

TTJ20 – Transportation Technology

Grade 10, Open

This course introduces students to the service and maintenance of vehicles, aircraft, and/or watercraft. Students will develop knowledge and skills related to the construction and operation of vehicle/craft systems and learn maintenance and repair techniques. Student projects may include the construction of a self-propelled vehicle or craft, engine service, tire/wheel service, electrical/battery service, and proper body care. Students will develop an awareness of related environmental and societal issues, and will explore secondary and postsecondary pathways leading to careers in the transportation industry. *(This course is normally offered to senior students. This course is offered in alternating years).*

TWJ3E – Custom Woodworking

Grade 11, Workplace Preparation

This course enables students to develop knowledge and skills related to cabinet making and furniture making. Students will gain practical experience using a variety of the materials, tools, equipment, and joinery techniques associated with custom woodworking. Students will learn to create and interpret technical drawings and will plan, design, and fabricate projects. They will also develop an awareness of environmental and societal issues related to the woodworking industry, and will explore apprenticeships, postsecondary training, and career opportunities in the field that may be pursued directly after graduation. *(This course is normally offered to senior students. This course is offered in alternating years).*

THJ10 – Exploring Green Industries

Grade 9, Open

This exploratory course introduces students to concepts and skills related to the green industries – agriculture, forestry, horticulture, floristry, and landscaping. Students will develop an awareness of related environmental and societal issues, and will begin to explore secondary and postsecondary pathways leading to careers in the field. *(This course is normally offered to senior students. This course is offered in alternating years).*

TCJ3C – Construction Technology

Grade 11, College Preparation

This course focuses on the development of knowledge and skills related to residential construction. Students will gain hands-on experience using a variety of construction materials, processes, tools, and equipment; learn about building design and planning construction projects; create and interpret working drawings and sections; and learn how the Ontario Building Code and other regulations and standards apply to construction projects. Students will also develop an awareness of environmental and societal issues related to construction technology, and will explore

career opportunities in the field. *(This course is normally offered to senior students. This course is offered in alternating years).*

FAMILY STUDIES

HNL2O HFN2O

HNC3C

HFN2O – Food and Nutrition

Grade 10, Open

This course focuses on guidelines for making nutritious food choices. Students will investigate factors that influence food choices, including beliefs, attitudes, current trends, traditional eating patterns, food-marketing strategies, and individual needs. Students will also explore the environmental impact of a variety of food choices at the local and global level. The course provides students with opportunities to develop food-preparation skills and introduces them to the use of social science research methods in the area of food and nutrition. *(This course is normally offered in grade 12.)*

HNL2O – Clothing

Grade 10, Open

This course introduces students to the world of clothing. Students will gain knowledge about clothing and demonstrate basic skills associated with various techniques and technologies used to create garments and accessories. Students will learn about the functions of clothing and accessories and what clothing communicates about the wearer. They will learn how to enhance their personal wardrobe by assessing garment quality, developing shopping strategies, and developing an understanding of the advantages and disadvantages of various retail formats. Students will develop research skills as they investigate topics related to clothing.

HNC3C – Understanding Fashion

Grade 11, College Preparation

This course introduces students to the world of fashion. Students will gain an understanding of theories related to fashion trends and of how culture, media, fashion cycles, retailing, and social and environmental factors influence fashion trends and consumer behaviour. Students will use various tools, technologies, and techniques safely and correctly to create fashion items. In addition, students will apply knowledge of fibres, fabrics, and the elements and principles of design when creating and assessing fashion-related products. Students will develop research skills as they investigate topics related to fashion.

CO-OPERATIVE EDUCATION

The Co-operative education program (“co-op”) offers Grade 11 and 12 students with the opportunity to earn credits through on-the-job experience. Co-op allows students to develop a greater understanding of their talents and so can help them make responsible decisions regarding further study or career options.

A cooperative education course is linked to a related course (or courses) from the Ontario curriculum. The course consists of a community-connected experience, the cooperative education curriculum, and a set of expectations from the related course. Students will learn about safety and well-being throughout the experience, and will create, implement, and reflect on, a learning plan that meets their interests and needs and supports education and career/life planning. Through the experience, students will apply and extend their learning from the related course, and

make connections with other aspects of their lives. For policy relating to cooperative education, see the section on cooperative education in the document *Community-Connected Experiential Learning*.

The daily out-of-school component of co-op is approximately 3 hours in length (or approximately 6 hours in the case of all-day co-op). Students earn 2 credits for a half-day co-op or 4 credits for an all-day co-op. For each two credits earned, the out-of-school component must be linked to an in-school component. These links must involve a course that the student has previously successfully completed.

Further information about the co-op program may be obtained from the co-op teacher or from Student Services.